

U.S. Pat. No. 7,117,602

The Veritas® Cabinetmaker's Trimming Plane has neither a toe nor a mouth, keeping the full-width blade exposed so that it can be used much like a bevel-edged chisel to work right up to an edge or into a corner. The 1 3/4" wide body provides extra control in confined areas, such as when working the inside of a cabinet. This trimming plane is also ideal for light trimming duties, such as removing glue lines or paring edge banding, pegs, plugs, dowels and box joints proud.

Made of fully stress-relieved, ductile cast iron, the body is accurately machined and ground so the sole is flat and the sides are square to the sole. The O1 tool steel blade is hardened to Rc58-60 and sharpened at a 20° bevel angle. The bevel-up configuration makes it easy to modify the cutting characteristics of the plane by simply adjusting the blade bevel angle. Set screws on either side of the blade prevent the blade from shifting in use.

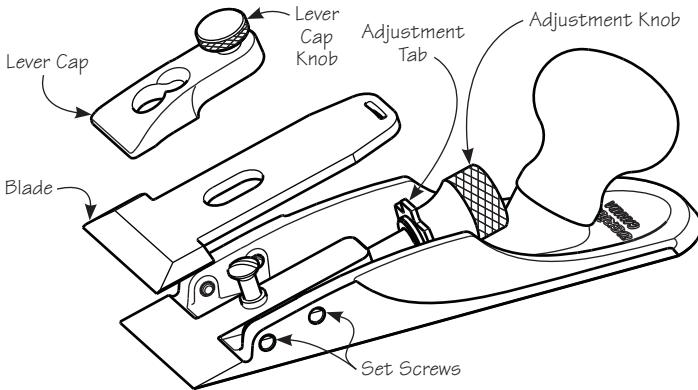

Figure 1: Plane components.

### Installing the Blade

**⚠ Caution:** Be aware that the blade is sharp; careless handling can result in serious injury.

Remove the lever cap, then rotate the adjustment knob so that the adjustment tab is facing up (see **Figure 1**). Place the blade (bevelled edge up) over the oval-head screw and onto the bed, taking care to insert the adjustment tab into the slot in the blade.

## Blade Sharpening

The cabinetmaker's trimming plane has a bed angle of  $15^\circ$  and the blade comes ground at an angle of  $20^\circ$ . Since the blade is used bevel up, the effective cutting angle will be  $35^\circ$ .

The  $20^\circ$  blade is ideal for long-grain work and for fine trimming work on end-grain softwood such as pine. End-grain work on hardwoods such as maple will require a  $25^\circ$  or higher bevel; ring-porous hardwoods such as oak may require a  $30^\circ$  bevel to prevent blade edge failure. Simply hone a micro-bevel to the desired angle.



**Tip:** A higher bevel angle will also reduce tear-out on figured woods.

**Note:** Be especially careful to keep the edge square to the blade when resharpening and honing the blade. The geometry of this plane does not provide allowance for skewing the blade relative to the body.

## Setting the Blade

To initially set the blade, place the plane on a flat wood surface (e.g., a scrap of stock). Lightly clamp the blade with the lever cap knob and advance the blade until it just touches the wood.

Flip the plane to a sole-up position, then sight along the sole to ensure the blade edge is parallel to the sole and advance or retract it such that it will take a light cut. (A trimming plane requires a fine blade depth setting, as it cannot take deep cuts without the possibility of tear-out.) Clamp fully (a quarter turn should be ample – **do not overclamp**) and take a test cut.

The ideal blade position will be achieved when the cutting edge is parallel to the sole and the blade corners are just proud of the side, as shown in **Figure 3**. This is most easily done with the four blade adjustment set screws (two on each side of the plane). Back off the lever cap knob just enough to free up the blade. Hold the blade against the left or right side set screws with your finger. Adjust these two set screws until the desired blade position is attained. When all is well, advance the other set screws until they just touch the blade, not to clamp it, but to create a guide so that you do not have to be concerned about the blade shifting sideways at the front. Once in position, the set screws will allow the blade to be adjusted for depth of cut, as well as allow it to be removed from the plane and then returned to its previously established position.

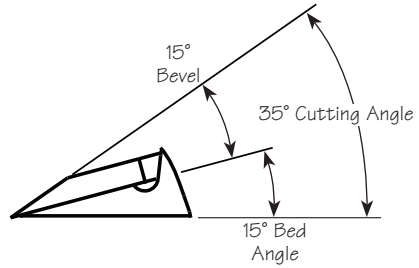

**Figure 2:**  $20^\circ$  blade geometry, as supplied.

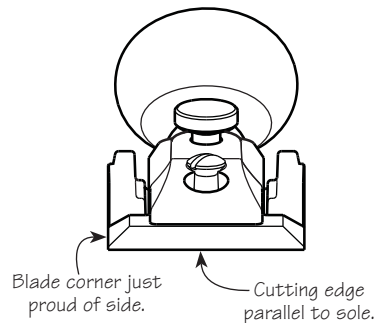

**Figure 3:** Setting the blade.

The blade is manufactured just slightly wider than the body to ensure a full-width cut. If you are working up to an edge, you may want to shift the blade so it is perfectly flush with (or just slightly proud of) the plane side that will contact the edge you are working.

## Two Cautionary Notes

1. The lever cap clamping knob has tremendous mechanical advantage. For normal use, it needs to be tightened only a quarter turn after full engagement with the blade. **Never torque it down as hard as you can or you may damage the plane.**
2. Because this plane has no toe, the blade edge is completely exposed. After use, the blade should be completely retracted for safe handling and storage.

## Care and Maintenance

The body of the cabinetmaker's trimming plane is ductile cast iron and comes treated with rust preventative. Remove this using a rag dampened with mineral spirits. Clean all machined surfaces.

We recommend that you initially, then periodically, apply a light coat of silicone-free paste wax to seal out moisture and prevent rusting (as well as act as a lubricant for smoother planing). Wipe off any wood dust from the surfaces that you will be waxing, apply a light wax coating, let dry, then buff with a clean soft cloth. At the same time, the solvents in the wax will remove any harmful oils left from your fingers that can lead to corrosion.

If storage conditions are damp or humid, the plane should, in addition to the treatment outlined above, be wrapped in a cloth or stored in a plane sack. This precaution will also guard against dings and scratches.

## Accessory

**05P74.02** Replacement O1 Blade